

ODYSSEY SERIES

Countertop Water Cooler - ECO Package

The Odyssey Series offers unparalleled value in bottled water coolers in both cool-and-cold and hot-and-cold configurations.



*Hot and Cold Units Only

KEY FEATURES

- Stylish front façade made from high quality durable plastic, coupled with steel side panels for strength.
- Compact design, ideal for homes, apartments, home offices and more.
- Easy-to-use taps, only one hand required.
- Food-grade, stainless steel tank and water contact tubes.
- Durable polypropylene, self-closing taps.
- Easy-to-clean, removable drip tray.
- 12-month standard warranty and additional 24 month. refrigeration system coverage
- Full range of replacement parts

The stylish **Odyssey Countertop Water Cooler** brings the ultimate flexibility to your home benchtop drinking water options. These convenient systems can either be used with refillable filter bottle (check out our Eco packages) or with pre-filled spring water bottles purchased from spring water companies.

Perfect for home and small office applications, the 2.0L cold tank cools down fast, ensuring you always have access to fresh, chilled drinking water. Our hot and cold model also dispenses water perfect for your cup of tea or noodles.

Available in;

Hot & Cold – The perfect mix of hot water for making coffee/tea and chilled water for keeping refreshed.

Cook & Cold – Chilled drinking water and Cook/Ambient temperature water ideal for cooking and other home applications.

Water Reservoir	Cold	2.5 L	Hot (if applicable)	1.5 L
Housing Material	High quality durable plastic with steel side panels			
Refrigeration	Uses R134A refrigerant			
Thermostat Control	The thermostat is factory set			
Capacity	Cold	2.0 L/h	Hot (if applicable)	5v.0 L/h
Power Consumption	Cold	85W	Hot (if applicable)	420W
Electrical	220V - 240V ~ 50Hz			
Weight (Packed)	10 kg			
Dimensions (Packed)	360w x 290d x 535h (W x D x H)			
Warranty	12-month comprehensive coverage. Additional 24-month refrigeration system coverage.			



Never buy bottled water again with the **Odyssey Series Countertop Eco Package Filtered Water Cooler**.

The package offers unparalleled value in bottled ambient and cold drinking water dispensers. Save money and stay environmentally-friendly with the Tri-Stage refillable water cooler bottle.

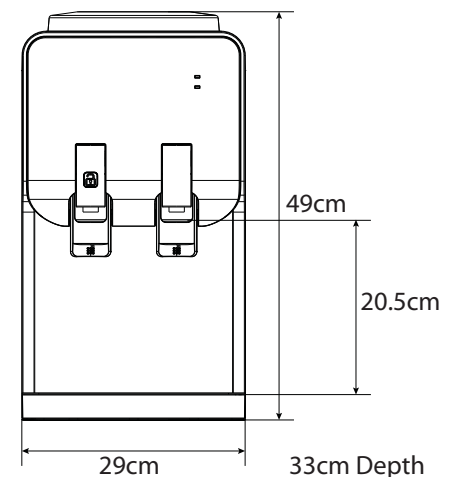

**AQUA
COOLER**

Your Partner in Cool.