

APOLLO 280 SERIES

Outdoor Drinking Fountain with Bottle Filler

The Apollo 280 (A280) drinking fountain features a robust design with both bubbler and bottle refill outlets. With its custom-designed stainless-steel basin and feature front panel, sand/debris resistant activator button, WaterMark certification, and AS1428 compliance options, the A280 is practical, stylish and complements any contemporary urban streetscape or park setting.



KEY FEATURES

- Australian made
- 316 Stainless steel front panel, bubbler, basin and catchment tray (optional)
- Strong 8mm mild steel construction
- Easy water activation system
- Unique designed sand/debris resistant activator button
- Bottle refill outlet as standard
- Disabled accessible (complies with AS1428 with longer basin and reduced height options)
- Vandal resistant
- Easy installation fixings and easy access for maintenance
- Customisable with many options
- Powder coated in premium Dulux steel shield coating finish
- Full parts and technical back up service

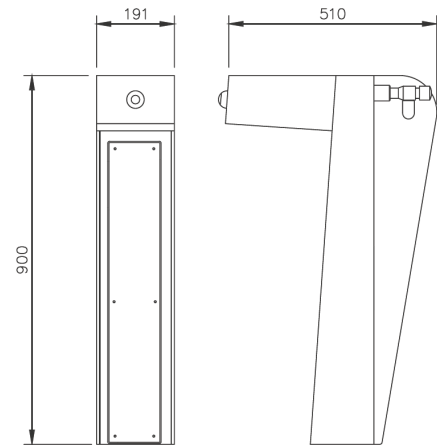

Technical Specifications

| | |
|------------------|---------------|
| Total Height | 900mm |
| Clearance Height | 800mm |
| Base | 191mm x 160mm |



Model Selection

| Model Selection | |
|---------------------------|--|
| AC-UFF-DFA280SSLBD | A280 Outdoor Fountain Stainless w/ Longer Basin + Tap & Dog Bowl |
| AC-UFF-DFA280SSLBC | A280 Outdoor Fountain Stainless w/ Longer Basin + Catchment Tray |
| AC-UFF-DFA280SSLB | A280 Outdoor Fountain Stainless w/ Longer Basin |
| AC-UFF-DFA280SSD | A280 Outdoor Fountain Stainless w/ Tap & Dog Bowl |
| AC-UFF-DFA280SSC | A280 Outdoor Fountain Stainless w/ Catchment Tray |
| AC-UFF-DFA280SS | A280 Outdoor Fountain Stainless Steel Standard (Bubbler + Bottle Refill) |
| AC-UFF-DFA280LBD | A280 Outdoor Fountain Powder Coated w/ Longer Basin + Tap & Dog Bowl |
| AC-UFF-DFA280LBC | A280 Outdoor Fountain Powder Coated w/ Longer Basin + Catchment Tray |
| AC-UFF-DFA280LB | A280 Outdoor Fountain Powder Coated w/ Longer Basin |
| AC-UFF-DFA280DB | A280 Outdoor Fountain Powder Coated w/ Tap & Dog Bowl |
| AC-UFF-DFA280C | A280 Outdoor Fountain Powder Coated w/ Catchment Tray |
| AC-UFF-DFA280 | A280 Outdoor Fountain Powder Coated Standard (Bubbler + Bottle Refill) |

Your Partner in Cool.

**AQUA
COOLER**

TECHNICAL SPECIFICATIONS

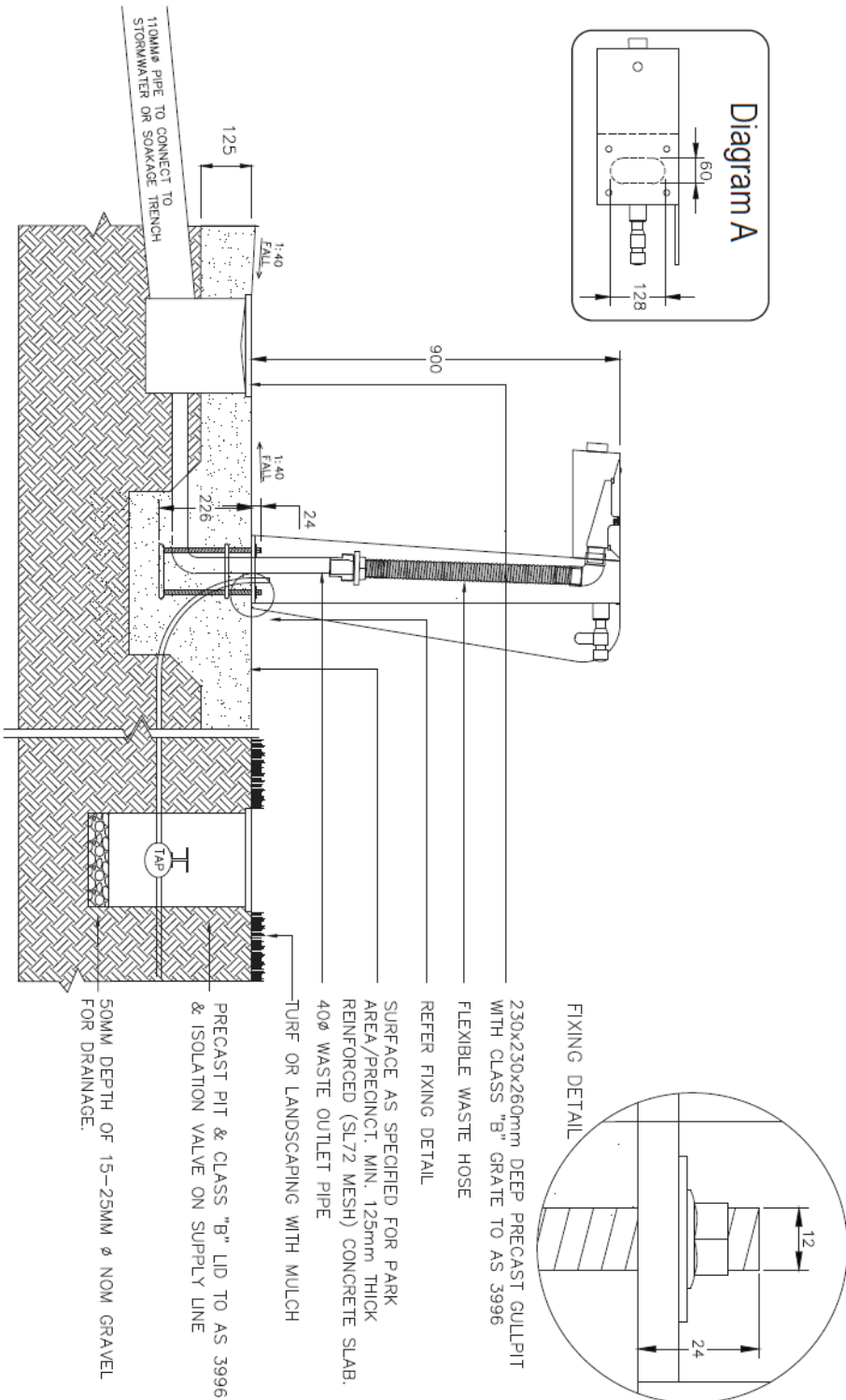

Your Partner in Cool.

**AQUA
COOLER**