

# H2O PRESTO CHILLER

## Under Bench Chilling Unit

The H2OPresto Chiller by Aqua Cooler is an innovative drink system designed to sit out of sight and dispense chilled water on demand.



### KEY FEATURES

- 5L/h chilled water output
- Simple to use, with automatic shutdown.
- Specifically designed for space-saving, under-bench installation.
- Fully insulated to achieve maximum energy efficiency.
- Easy filter replacement with a single twist.
- 12-months standard warranty.
- Full range of replacement parts.



The H2O Presto Under Bench Unit is designed small to easily fit under your sink, saving you floor and bench space. The unit outputs 5L/h of chilled water and can be paired with an optional filter kit. Pair this unit with our H2O Presto Boiling unit to create a complete underbench package.

Aqua Cooler products are manufactured from the highest quality components supplied from the industry's leading suppliers and designed to run efficiently with low maintenance.

### Model Selection Chart

Name	Temperature	Colour	Faucet	Filtered	SKU
H2O Presto - Chiller	Chilled	Black	-	-	H2OP-CHILL-BLK
H2O Presto - Chiller	Chilled	Black	-	Filtered	H2OP-CHILL-BLK-F
H2O Presto - Chiller	Chilled	Black	Included	-	H2OP-CHILL-BLK-T
H2O Presto - Chiller	Chilled	Black	Included	Filtered	H2OP-CHILL-BLK-F-T
H2O Presto - Chiller	Chilled	White	-	-	H2OP-CHILL-WHT
H2O Presto - Chiller	Chilled	White	-	Filtered	H2OP-CHILL-WHT-F
H2O Presto - Chiller	Chilled	White	Included	-	H2OP-CHILL-WHT-T
H2O Presto - Chiller	Chilled	White	Included	Filtered	H2OP-CHILL-WHT-F-T
H2O Presto - Combo	Hot / Chilled	White	Included	-	H2OP-PACK
H2O Presto - Combo	Hot / Chilled	White	Included	Filtered	H2OP-PACK-F

# TECHNICAL SPECIFICATIONS

Cold water	Water inlet	1/4" quick connect fitting
	Water outlet	1/4" quick connect fitting
Tank capacity	4L	
Tank material	Stainless steel 304	
Refrigerant	60g R134a	
Electrical	220 - 240V 50Hz	
Power	150W	
Weight	12 kg	
Max Pressure	400kpa	
Min Pressure	20kpa	
Dimension	18(W) x 31.5(D) x 38(H)cm	
Warranty	Twelve-month comprehensive coverage.	

This unit is supplied with a pressure limiting valve. Please install the valve between the water source and inlet during installation.

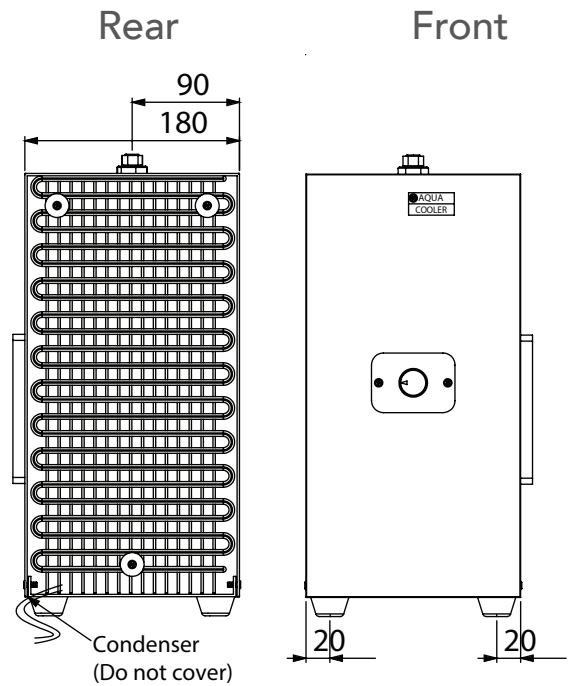

Top

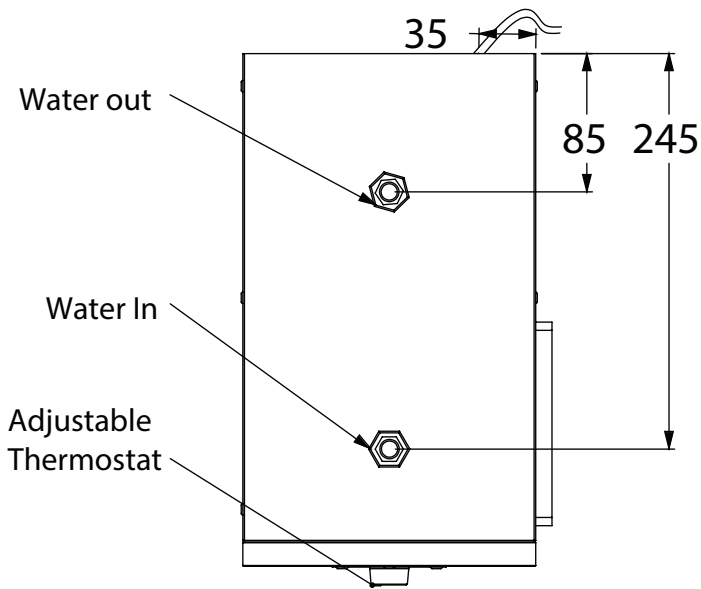

Side

