

## AC Series Self Contained Gourmet Ice Machines – up to 51kg

**ACM 107 AS** Medium gourmet cube 20g, Ø30mm x 34mm



Medium gourmet cube  
20g, 30mm dia x H 34mm



Note: Ice production rate is measured with the water temperature at 10°C and an ambient temperature of 21°C.

- Up to 51kg daily production rate
- 23kg storage bin capacity
- Air cooled version
- Produces individual transparent Gourmet crystal clear supercubes
- R290 refrigerant gas
- Agion Technology resists the growth of microbes and the development of unpleasant odours
- Simple, reliable electromechanic controls
- Horizontal ice evaporator spray-system technology
- Resistant stainless steel exterior
- Front access condenser air filter, removable and washable
- Routine maintenance visible alarm light on front panel
- Ergonomically designed ice storage access with disappearing door and door closing movement dampening system
- Includes removable air filter, ice scoop, water and drain hose
- Optional adjustable feet available up to 850mm high

### AC Series Self Contained Gourmet Ice Machines – up to 51kg

#### ACM 107 AS

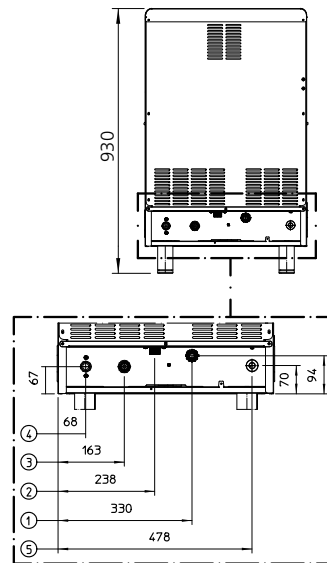
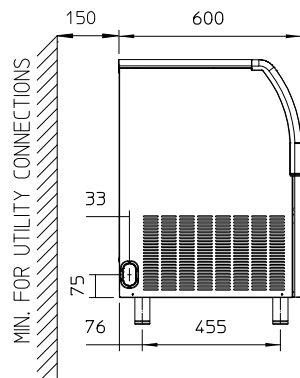
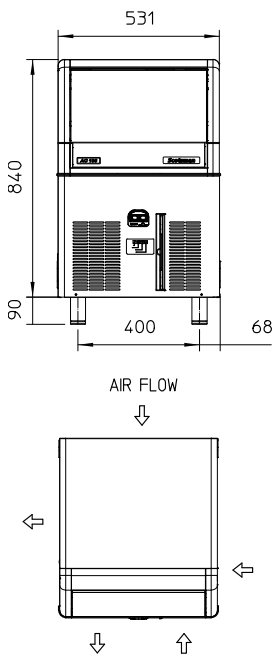

- UNIT OF MEASUREMENT: mm
1. 25/32" OD - OVERFLOW DRAIN
  2. 3/4" GAS - WATER INLET
  3. 3/4" GAS - WATER OUTLET  
WATER COOLED UNIT ONLY
  4. 3/4" GAS - WATER INLET  
WATER COOLED UNIT ONLY
  5. CORD SET



moffat.com.au

Australia  
Moffat Pty Limited  
Victoria/Tasmania  
740 Springvale Road  
Mulgrave, Victoria 3170  
Telephone 03-9518 3888  
Facsimile 03-9518 3833  
vsales@moffat.com.au

New South Wales  
Telephone 02-8833 4111  
nswsales@moffat.com.au

South Australia  
Telephone 03-9518 3888  
vsales@moffat.com.au

Queensland  
Telephone 07-3630 8600  
qldsales@moffat.com.au

Western Australia  
Telephone 08-9413 2400  
wasales@moffat.com.au

#### Ice production per 24 hours

Ambient temperature / Water temperature

10°C / 10°C	21°C / 10°C	32°C / 21°C
53	51	43

#### Dimensions

Width: 531mm  
Depth: 600mm  
Height: 930mm (including legs)  
Nett weight: 47kg  
Packed weight: 54kg

#### Water consumption

Air cooled version: 5.2 litres per hour

#### Electrical rating

Air cooled version: 230-240V, 50Hz, 580W,  
10A cordset supplied  
No. Circuit wire: 3  
Compressor: 1215W  
Energy consumption: 10.7kW/24hr

#### Refrigerant type

R290

#### Installation distance from wall

Rear 150mm  
Sides 150mm  
Operating requirement air temperature 10-43°C

#### Water connection requirements

Inlet connection: R 3/4"  
Cold water: 5-38°C  
Pressure: 100-500kPa  
Water outlet connection: Ø3/4"

#### Important Notice:

Models and specifications are subject to change without notice. This spec sheet is meant for commercial purpose only. For technical documentation please refer to our service manuals.



© Copyright Moffat Ltd  
AU.SM.2301