



SEMI-RECESSED BOTTLE FILLER

Usage and Care Manual

Models: AC-MWSM8EBFY-ASM

Your Partner in Cool.

AQUA
COOLER

PRODUCT DIAGRAM

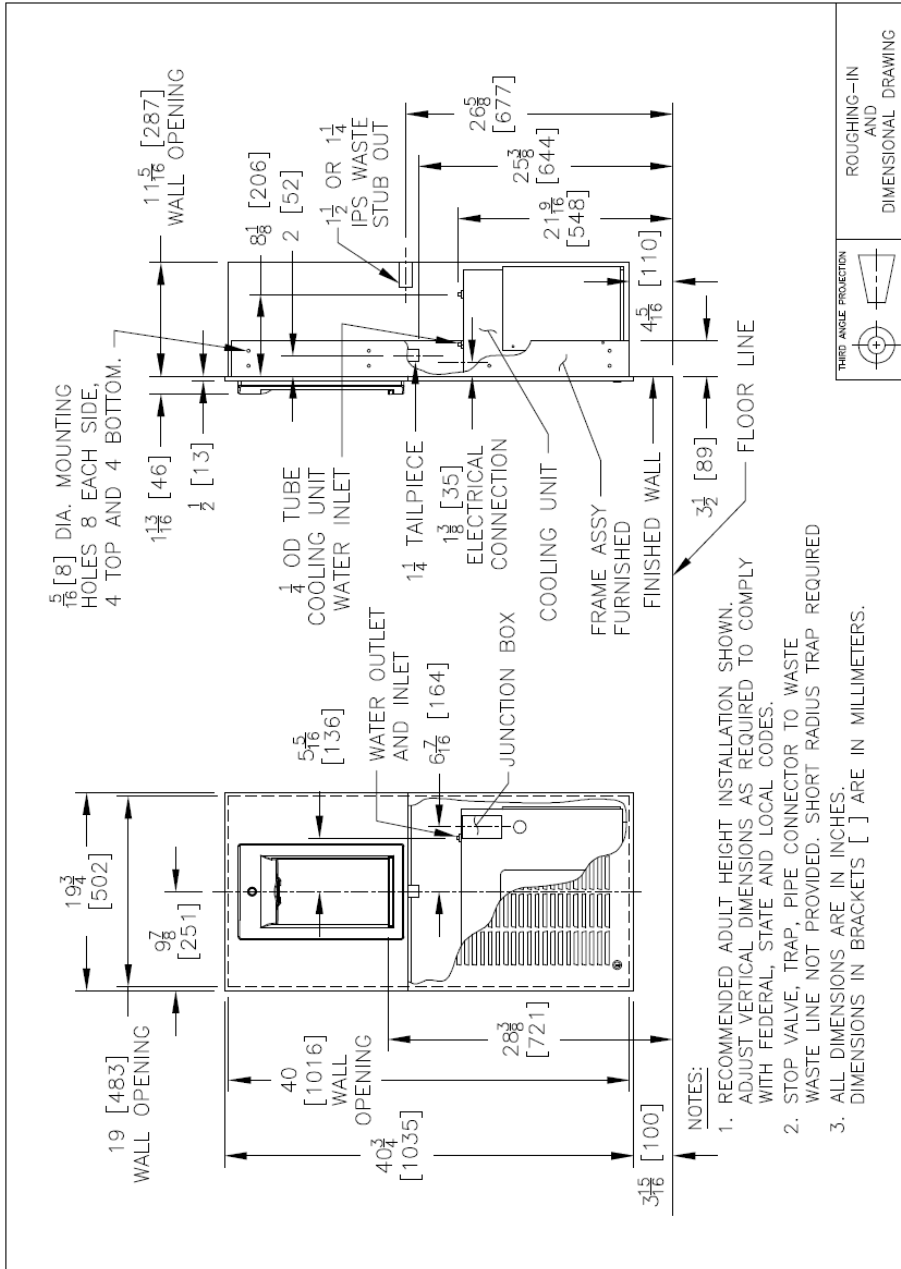

BOTTLE FILLER ASSEMBLY

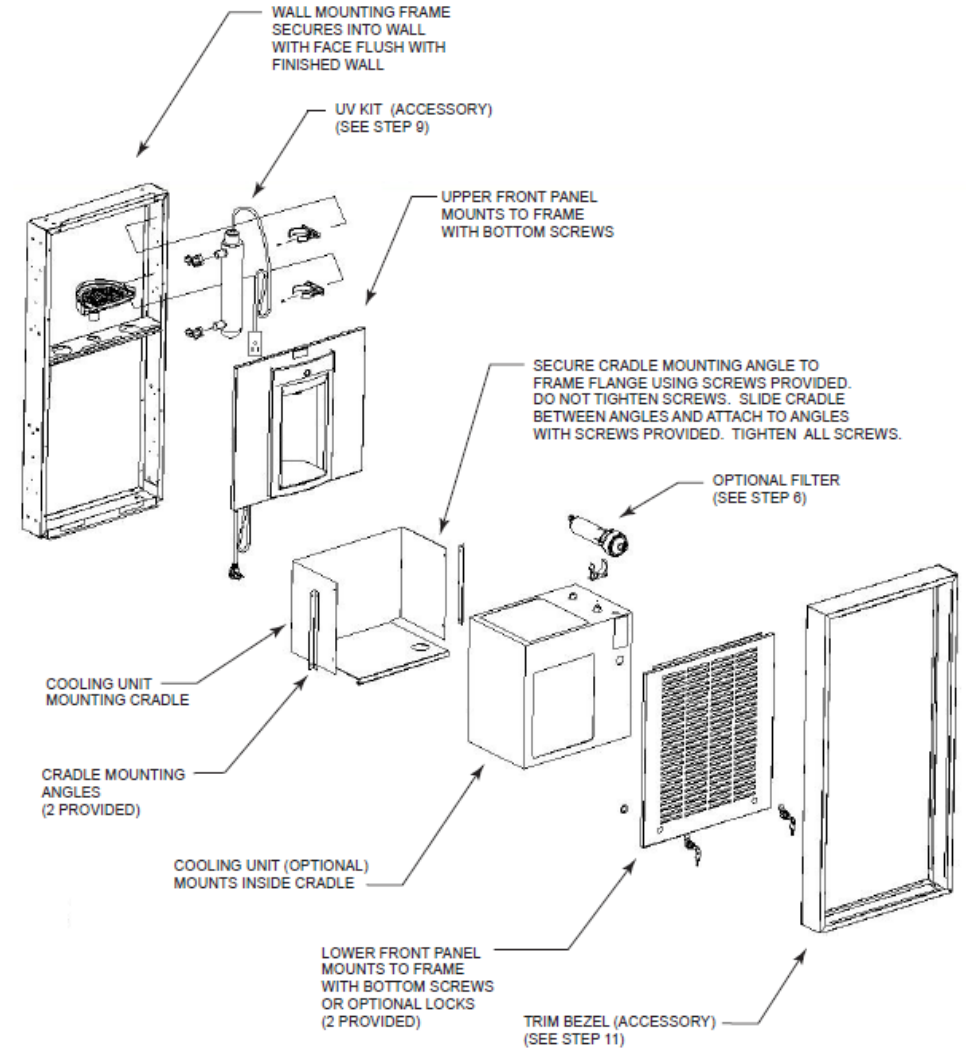

IMPORTANT SAFETY INSTRUCTION

When using electrical appliances, basic safety precautions should be followed to reduce the risk of fire, electric shock and injury to persons or property. Read all instructions before using any appliance.

- Keep combustible material such as furniture, bedding, pillows, clothes and/or papers away from the unit.
- Do not operate this, or any other appliance, with a damaged power cable.
- No other appliance should be connected into the same power supply.
- Do not run the power cable over carpeting or other heat insulators.
- Keep the power cable away from high traffic areas.
- Do not submerge the power cable in water.
- We do not recommend the use of joint cables as they may overheat and increase the risk of fire.
- Exercise caution and use reasonable supervision when the appliance is used by or near children.
- Keep a minimum distance on each air-louvre side free.
- Do not use this product to dispense anything other than water.
- Do not use this product to dispense anything other than water.
- This appliance must be installed on an even and flat surface or wall.
- If the power cable or terminal is damaged, one of its service agents or a similarly qualified person must replace it to avoid hazard.
- Switch off the main power source before servicing the appliance.
- Warranty will be voided if installation is not carried out as detailed in this instruction manual.
- The compressor motor is equipped with an automatic reset protector which will disconnect the motor from the line in case of an overload.

IMPORTANT INFORMATION ABOUT GROUNDING

- To provide additional protection from the risk of shock, this unit must always be connected to a residual-current device (RCD) or a breaker. Use of joint cable should be avoided.
- This appliance must be grounded. Improper use of the grounding plug can result in a risk of electric shock, causing serious injury and possibly death.
- This appliance is equipped with the power terminal or power cord. A ground connection must be connected into a properly grounded, polarised outlet.
- Consult a qualified electrician if the grounding instructions are not completely understood, or if doubt exists as to whether the appliance is properly grounded.
- Do not under any circumstances cut or remove the third (ground) prong from the power cord plug (if provided). Do not use an adapter plug with this appliance.

INSPECTION

Inspect the cartons and various components for evidence of rough handling and concealed damage. Damage claims should be filed with the carrier.

INSTALLATION

The installation must be in accordance with AS/NZS 3500.1 and AS/NZS 3500.2, as well as the instructions below. Pipe jointing and installation is a trade skill and Aqua Cooler recommended this process is performed by qualified personnel only.

Plumbing rough-in and wall opening should be prepared as shown on roughing-in drawing.

Insert frame assembly into wall opening and secure to studs. NOTE: FRONT FLANGE OF FRAME(S) MUST BE FLUSH WITH THE FINISHED WALL SURFACE.

Install drain receptor to frame with screws provided.

A 2X4 junction box is provided for the installation of a 115 volt receptacle. The bottle filler is provided with a power cord with a grounded NEMA 15 plug. It is recommended that flexible conduit be used to supply power to the junction box and chiller if used. Check the electric current available. Type and voltage must be the same as listed on the unit data plate.

Refer to the appropriate connection diagram for water and drain connections. Check for leaks.

The lower panel can be secured with the provided key locks or screws. The M8SBF features one lockable and one non lockable lower panel, these are interchangeable.

MODELS WITH CHILLER

Attach cradle mounting angles to unit mounting cradle with 4 screws provided. Slide unit mounting cradle into frame and secure in place with 4 screws, provided. (Cradle is used only when cooling unit is to be installed.) NOTE: BOTTOM FLANGE ON CRADLE IS TO BE BEHIND FRAME FRONT FLANGE.

Slide cooling unit onto cradle.

INSTALL MOUNTING FRAME

- A - Install frame per rough in drawing
- B - Install drain assembly
- C - Install snap bushings

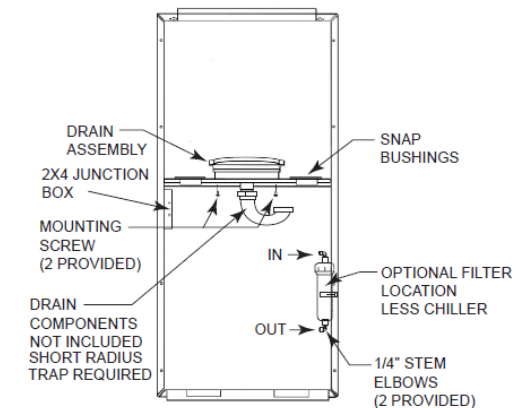

INSTALLATION CONT.

CONNECTING THE CHILLER

- A - Attach cradle to frame per rough-in drawing
- B - Place chiller in frame
- C - Install 1/4" union fittings on chiller inlet and outlet
- D - Run the water line from the bottle filler solenoid valve "out" to chiller "in". Cut off excess and use it to run from chiller "out" to the bottle filler delivery tube.

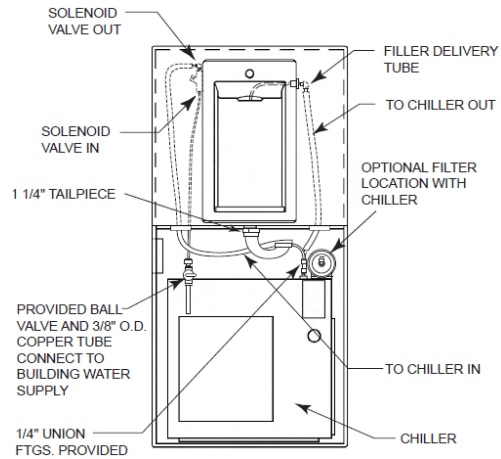

FILTER LOCATION

- A - Screw filter clip to unit in location as shown. (screw provided)
- B - Install 1/4" stem elbows (provided) in filter inlet and outlet
- C - Place filter in clip as shown below.

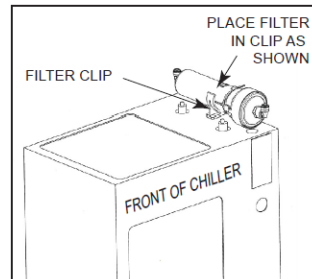

FILTER INSTALLATION

- A - Mount filter clip to frame
- B - Install provided stem elbows
- C - Cut water line from solenoid valve to bottle filler delivery tube.
- D - Connect solenoid valve out to filter in
- E - Connect filter out to filler delivery tube

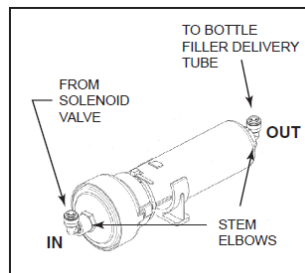

INSTALLATION CONT.

TRIM BEZEL INSTALLATION

- A - Install frame assembly to a flat surface. Use appropriate fastening hardware (not included). Refer to front of instruction manual for correct installation height.
- B - Remove bottom plate from trim bezel (4 screws)
- C - Install trim bezel to frame assembly and replace bottle plate with screws
- D - Install drain assembly, snap bushings and any other accessories included with this kit.
- E - Install upper and lower front panel.

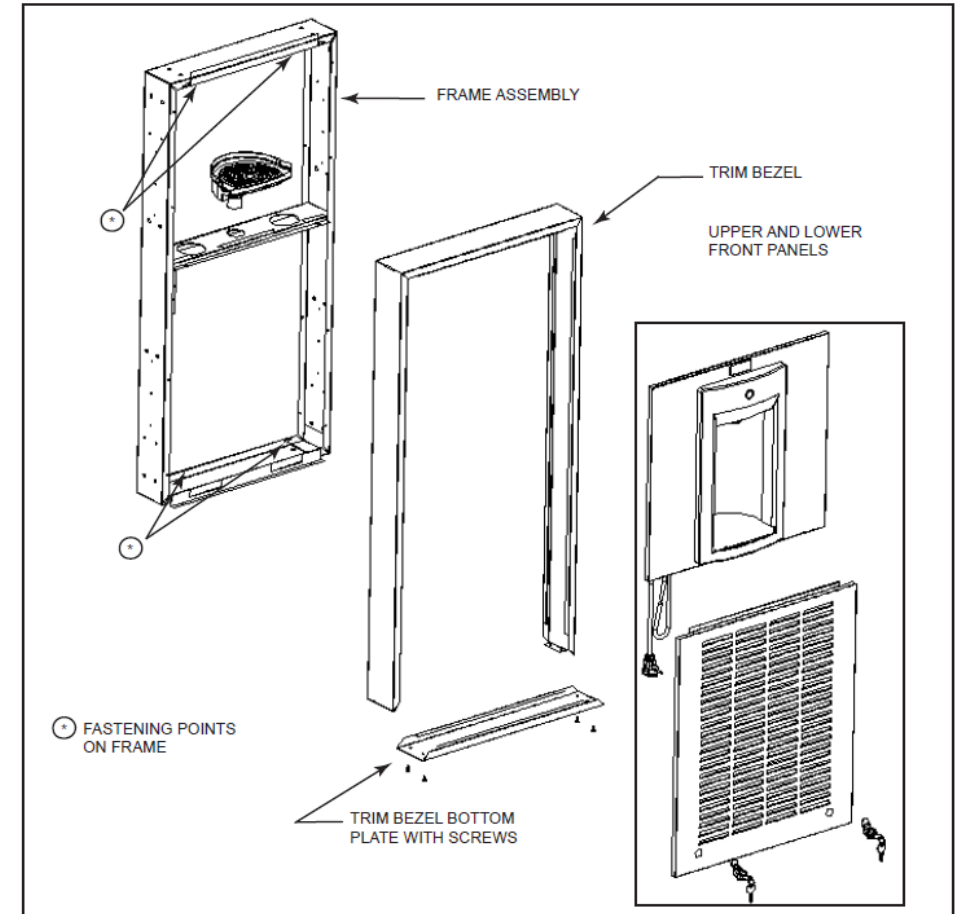

SPARE PARTS

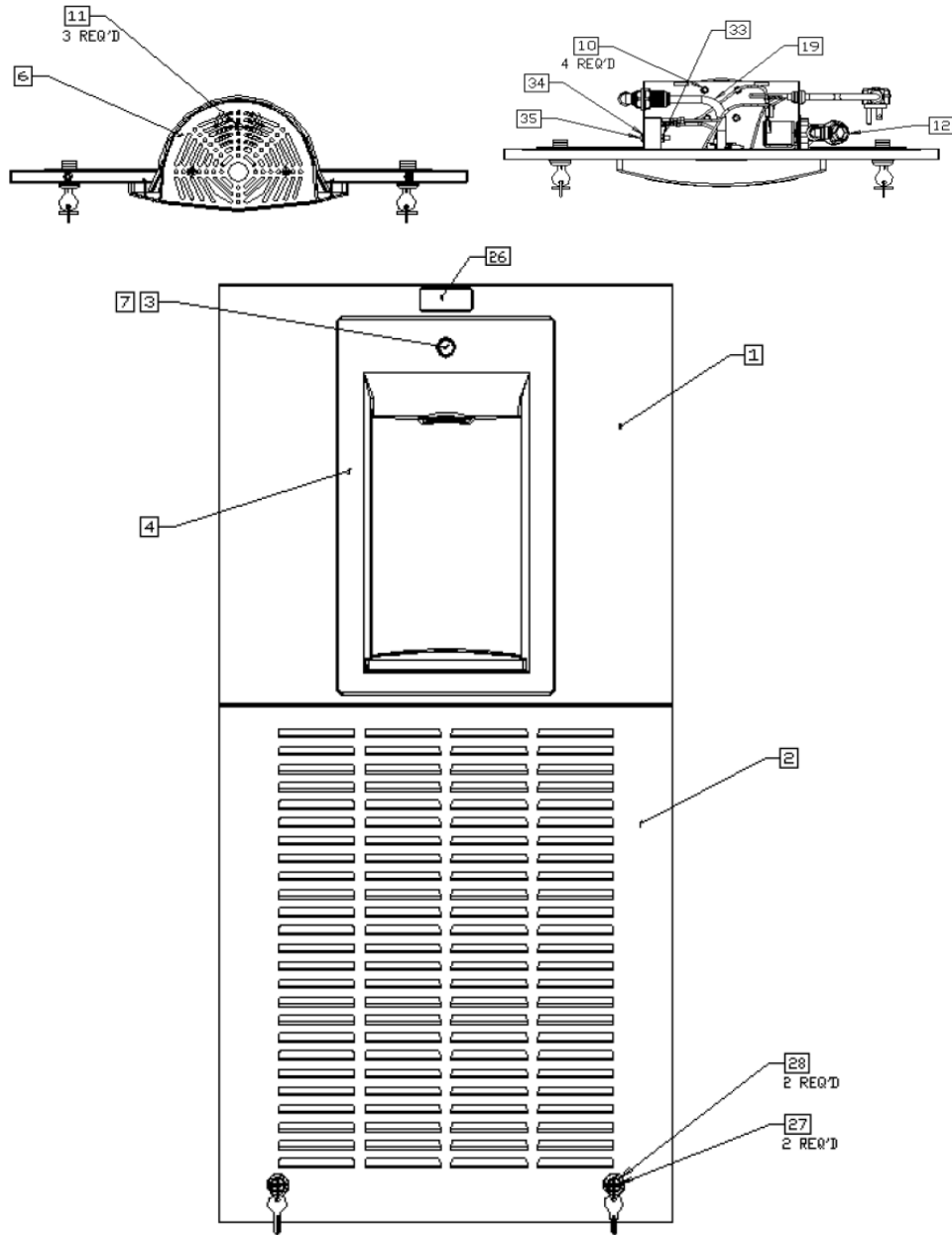

SPARE PARTS

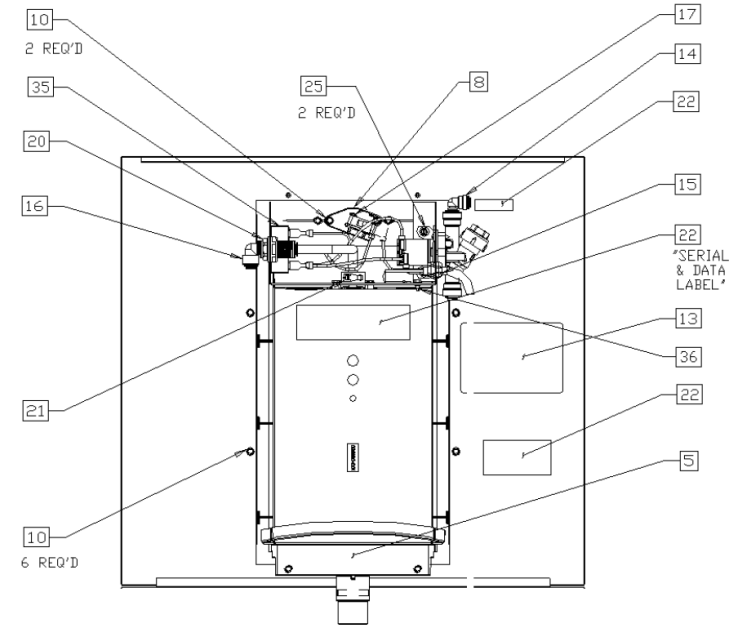

Desc	Part #	Qty	Desc	Part #	Qty
1 Panel, Bottle Filler Upper	027624-401	1	19 Tube, Fill	036208-001	1
2 Panel, MWSBF Lower Louver Stn	027697-005	1	20 FTG, JG. Bulkhead Union 3/8	028913-001	1
3 Spring, MSBF	034649-001	1	21 Tie, Cable 6"	024070-006	1
4 Alcove, MSBF	036190-001	1	22 Label Group, Carton & Unit	029583-005	1
5 Drain, MSBF	036191-001	1	23 Angle, Cradle MTG	026210	2
6 Grille, MSBF	036192-001	1	24 Bag, Plastic	027270-003	1
7 Button, MSBF	036194-001	1	25 Screw, Hex HD Tapping	026642-023	2
8 Mount, Switch	036195-001	1	26 Insert, N' Plate Oasis Gel BA	020850-004	1
9 Shelf, Activation MSBF	036197-001	1	27 Lock Assy With Cam	031657-004	2
10 Screw, Hex HD Tapping	026642-003	14	28 Washer For Compx Lock	031657-005	2
11 Screw, Flat HD Tapping	026675-003	3	29 Packaging Group BF	036466-001	1
12 Solenoid Valve	201828-01	1	30 Elec Ckt Dwg W/ Lead Wire P/N	036471-001	1
13 Label, Wiring Diagram MSBF	030939-002	1	31 Kit, BF Accessories	036470-001	1
14 FTG, JG. Elbow, Plug In Whi	029994-103	1	32 Screw, RD HD Machine	026660-006	1
15 Bushing, Strain Relief SR6P34	019008	1	33 Nut, Hex	026824-006	1
16 FTG, JG. Elbow, Plug In	029139-001	1	34 Lockwasher, External Tooth	021413	1
17 Screw, Pan HD Tapping Type AB	026630-039	1	35 Timer, Solid State 60 Sec	090973-003	1
18 Cover, Activation Shelf	036207-001	1	36 Screw, Hex HD Machine	026670-028	2

WARRANTY & SERVICE REGISTRATION

For All Aqua Cooler Water Cooler and Fountain Products

Effective July 2017

Aqua Cooler Pty Ltd warrants this appliance to the first purchaser as follows and subject to the stated conditions.

12 Month Comprehensive Warranty - Any defect in the appliance occurring within the first twelve months from the date of purchase will be rectified free of charge by Aqua Cooler Pty Ltd or by any authorised independent Service Agent.

24 Month Extended Warranty - Aqua Cooler Pty Ltd agrees to replace any part of the hermetically sealed refrigeration system which becomes inoperative in the two years following the first years comprehensive warranty. This extended warranty covers the compressor, condenser, and interconnecting refrigeration pipework. It excludes compressor relays, overloads and all other components of this appliance. This extended warranty does not include service, repair or labour costs or any pickup and/or freight charges. Aqua Cooler at its sole discretion may replace the cooler with a new or refurbished cooler of a similar age.

Warranty Exclusions

1. Any costs associated with the removal and reinstallation of repaired or replaced units.
2. Travel expenses to locations further than 100km from any Australian Capital City CBD or further than 100km of a registered Service Agent.
3. Damage to units where mains connected pressure is higher than 700kPa and a pressure limiting valve is not installed.
4. Where the unit is not installed as per installation instructions found within the supplied user manual.
5. The warranty does not cover defects occasioned by misuse, alterations, accident or where the water cooler has been stored on its side.

**FOR ANY CLAIMS UNDER THIS WARRANTY PLEASE CONTACT AQUA COOLER PTY LTD
PHONE: +61 (02) 9721 9300 OR EMAIL: support@aquacooler.com.au**

Thank you for your custom and we hope our product provides many years of fault free operation. To enable us to register your warranty and provide the best possible service should a problem occur, we recommend you fill out the section below and return it to us immediately.

This warranty is provided in addition to other rights and remedies you have under law: Our goods come with guarantees which cannot be excluded under the Australian Consumer Law. You are entitled to replacement or refund for a major failure and to compensation for other reasonably foreseeable loss or damage. You are also entitled to have the good repaired or replaced if the goods fail to be of acceptable quality and the failure does not amount to a major failure.

Warranty & Service Registration Form

Please fill in this form and mail to us or send via email to support@aquacooler.com.au. If this form is not completed and returned the warranty period will be deemed to have commenced from date of manufacture.

COMPANY NAME (if applicable):	
CONTACT NAME:	PHONE NUMBER:
ADDRESS:	
SUBURB:	POSTCODE:
MODEL NUMBER:	SERIAL NUMBER:
PURCHASED FROM:	
DATE OF PURCHASE:	

Your Partner in Cool.



**AQUA
COOLER**

Your Partner in Cool.

Phone Numbers

Sales: 1300 278 226
Service: 1800 278 226

Address

U14, 2-12 Knobel Court
Shailer Park QLD 4128

Internet

www.aquacooler.com.au
info@aquacooler.com.au